

LEADWELL
LEADWELL CNC MACHINES MFG.,CORP.

TM-1500

Multi-tasking Machine

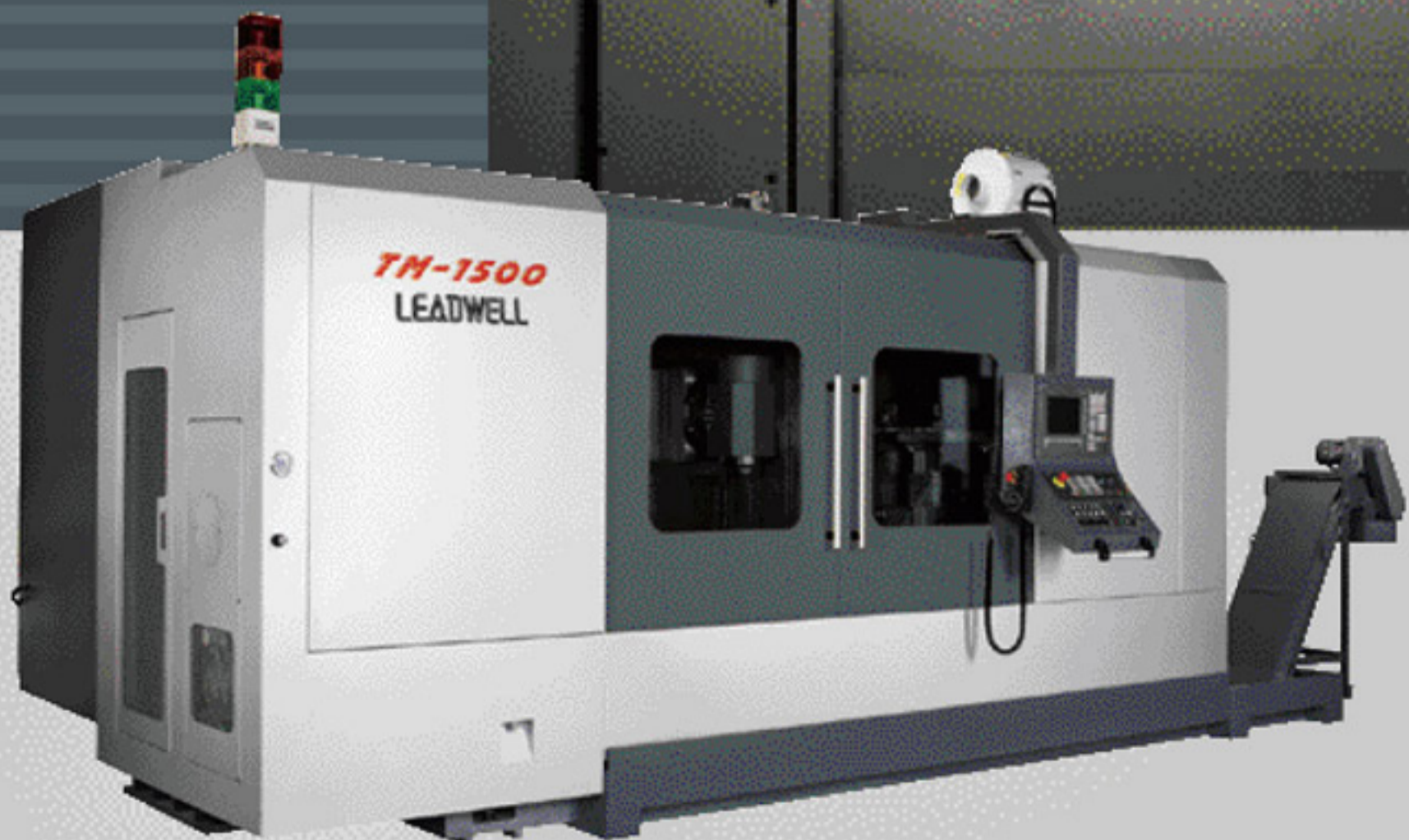

www.leadwell.com.tw

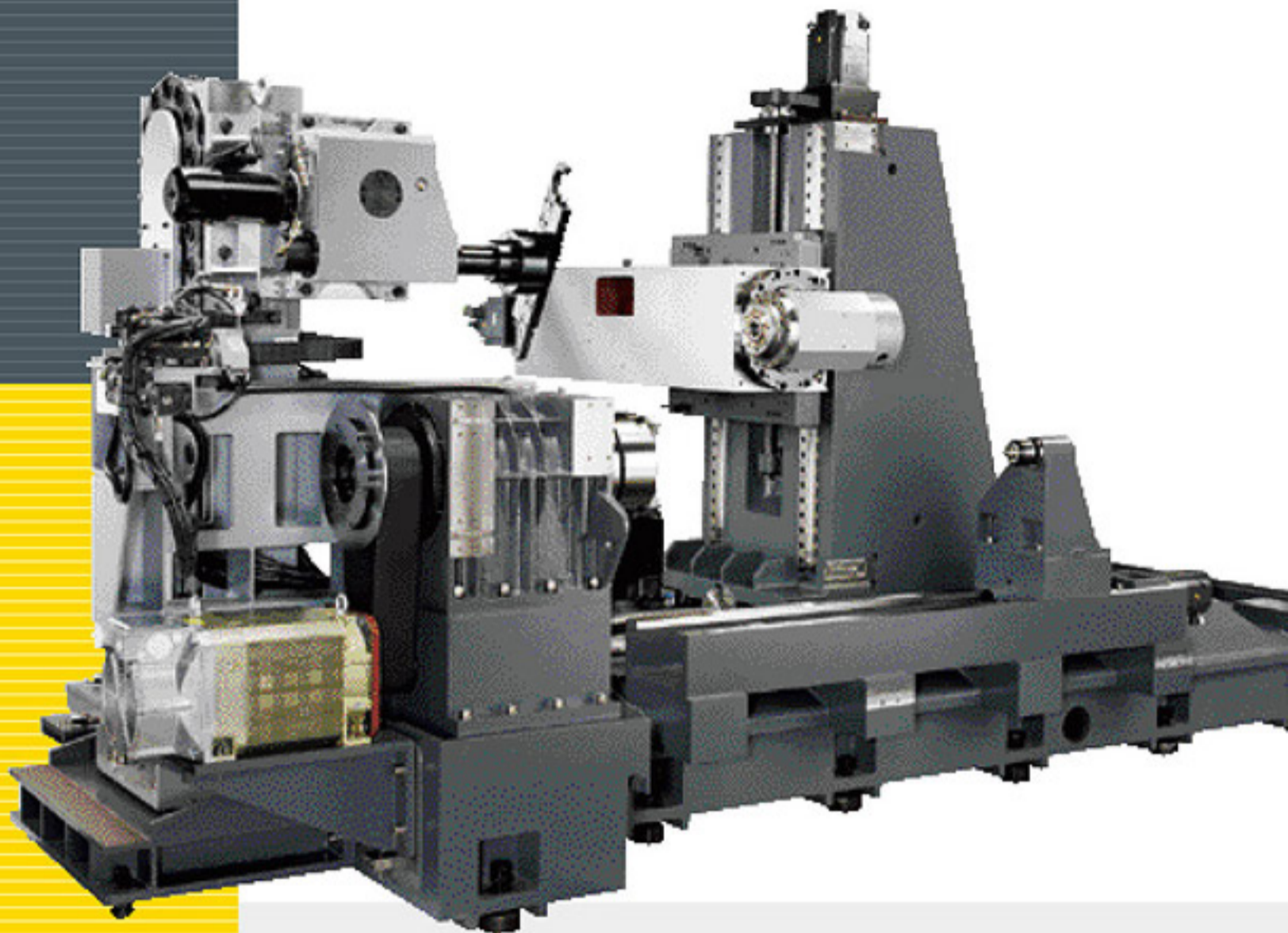

TM-1500

Multi-tasking Machine

The Feature of the TM-1500

- *The multi-function machine with B-axis can easy have bevel angle drilling and cutting work.*
- *The machine use special Electro Spindle, the spindle speed can reach 12000rpm and torque 103Nm, it is a special machine can do first mill and end mill in the same machine.*
- *The Y-axis design is perpendicular type, and match with our moving column machine structure, the Y-axis have complete movement. It will not have dead space for the travel. (Y-axis travel +/-220mm).(applying for patent now.)*
- *12" chuck (C-axis) + servo tailstock (M.T #5) + 40 tools ATC (Capto C6) + 1550mm Z-axis travel + B-axis (-10°~+230°)=Perfect machine.*

High Quality Assurance

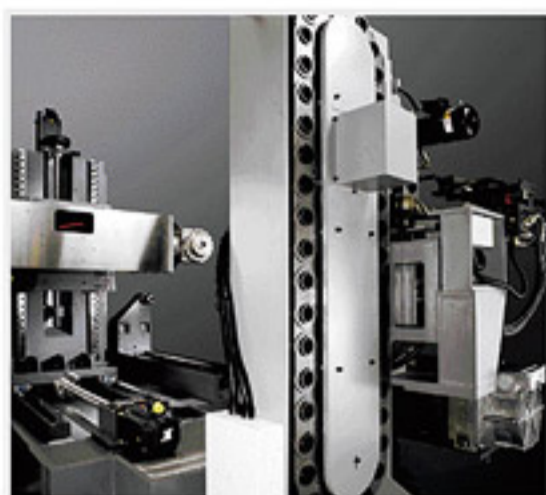

• 40 Tool ATC



• SIEMENS 840D Control Type



-10°



45°



90°



135°



230°

■ B axis travel 240° (-10°~+230°)

- The B-axis is driven by DD build-in motor, the best torque is 1200Nm, and with curved coupling it can easy do a heavy cutting job shop work and also curved surface milling.

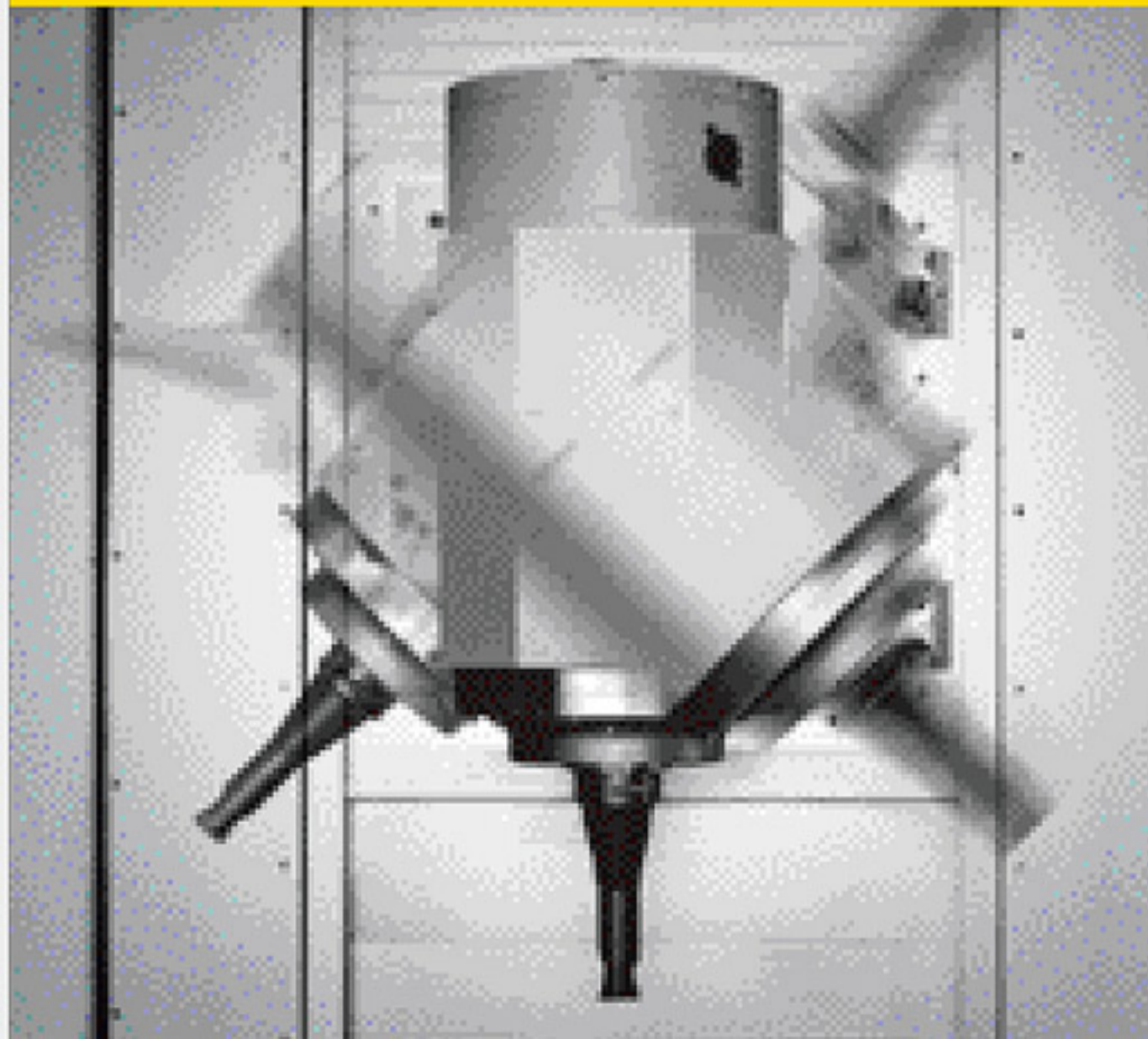

High Productivity (Options)

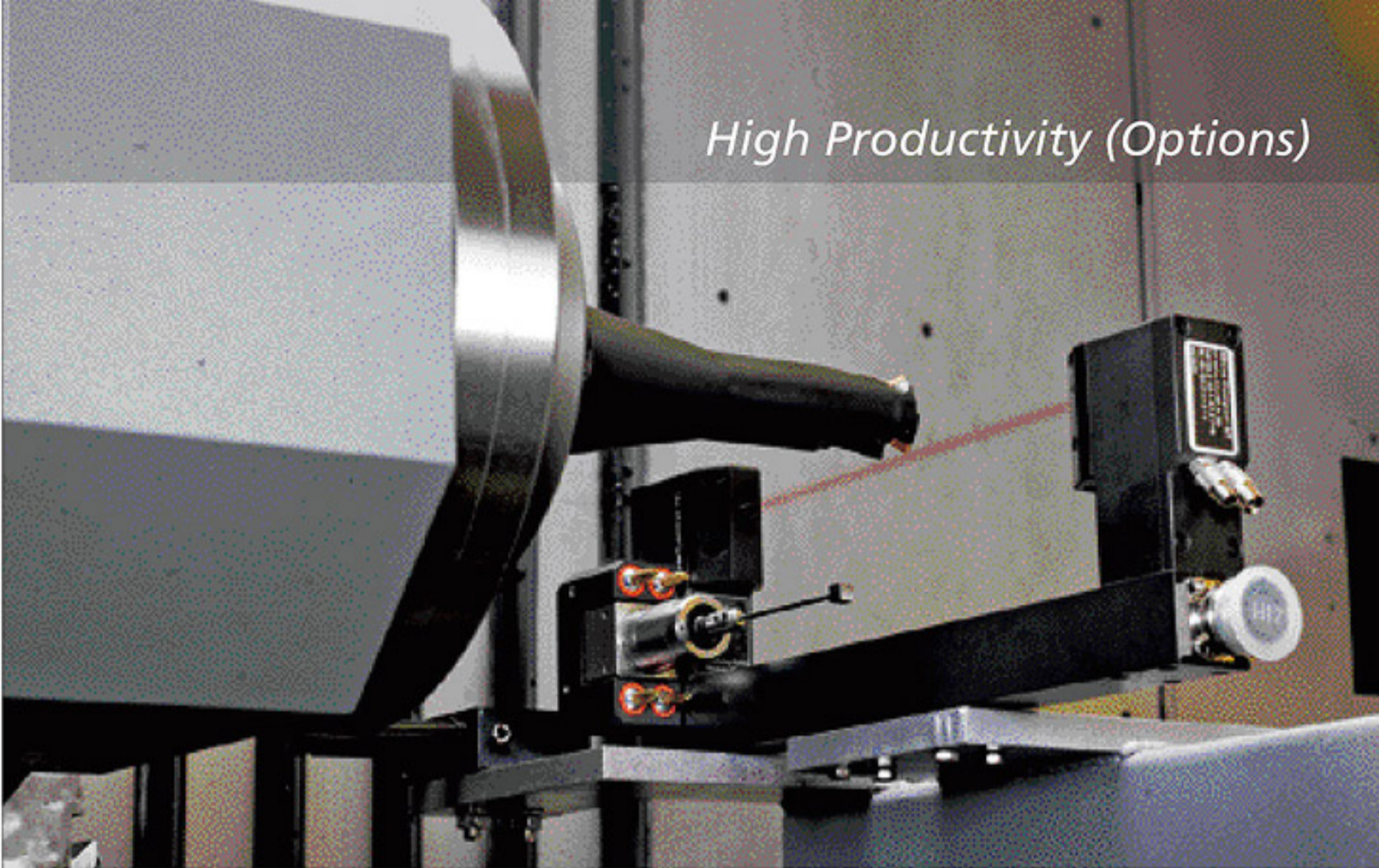

- Touch Sensor For Work Piece (option)



- Oil mist collector (option)



- Oil Skimmer (option)



- 70 Bar High Pressure Pump (option)



- Laser Carving & Heat Treatment (option)



- Automatic Tool Measurement (option)

SPINDLE SPEED / OUTPUT DIAGRAM

TM-1500 chuck spindle motor torque drawing

TM-1500 electrospindle motor torque drawing

TM-1500 tablemotor torque drawing

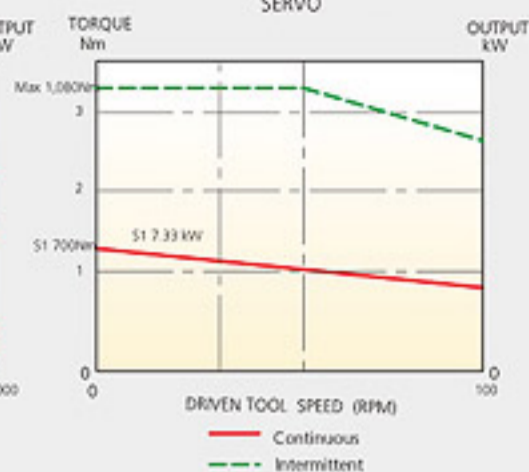
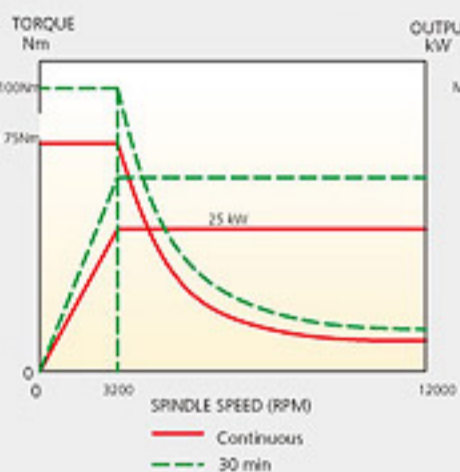
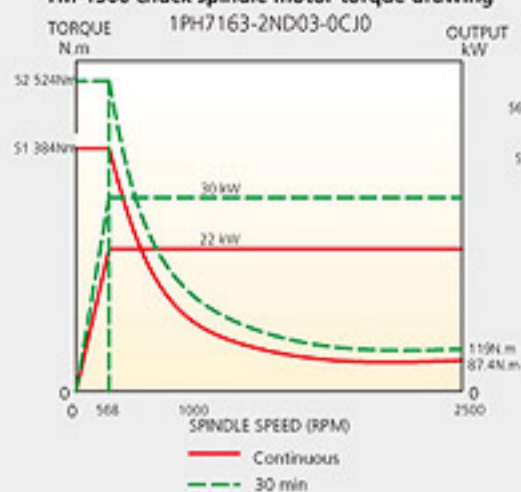

MACHINE DIMENSIONS

Unit:mm

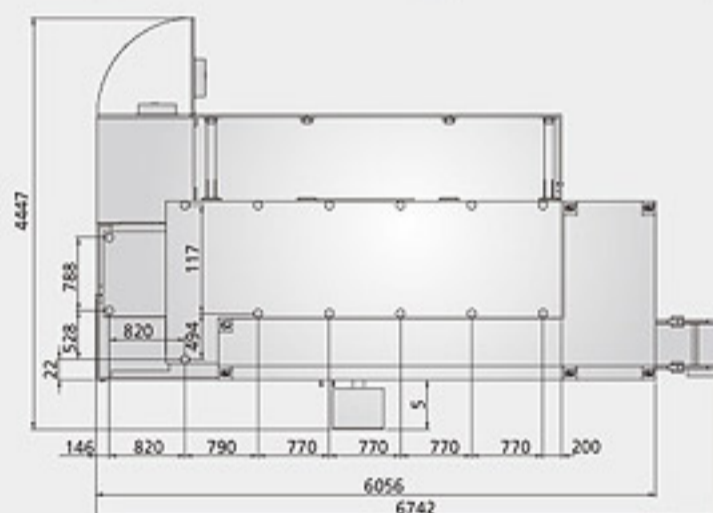
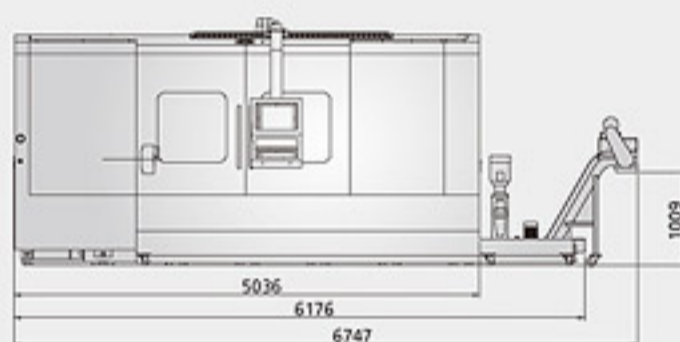
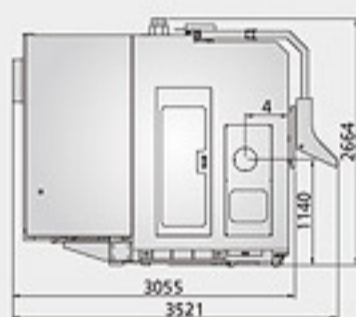

WORKING CAPACITY

Unit:mm

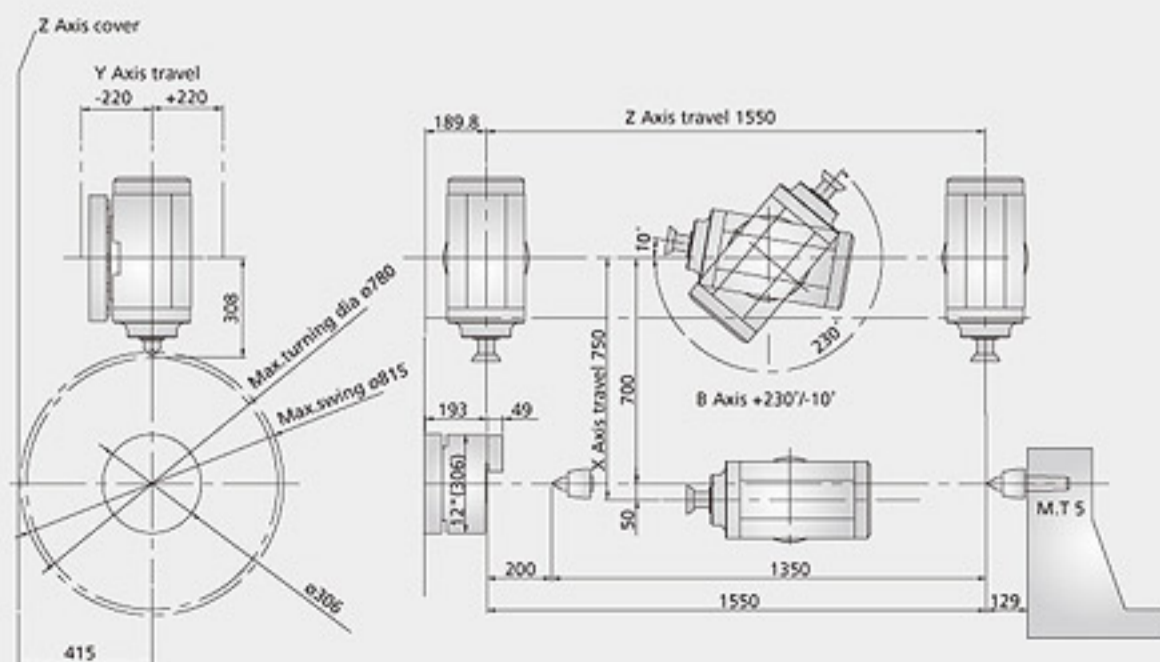

MACHINE SPECIFICATIONS

ITEM	MODEL	TM-1500
CAPACITY		
	Unit	
Max. swing	mm(in)	ø815 (32)
Max. turning diameter	mm(in)	ø780 (30.7)
Max. turning length	mm(in)	1500 (59)
Bar capacity	mm(in)	ø85 (3.3)
TRAVEL		
X axis	mm(in)	700+50 (27.5+2)
Z axis	mm(in)	1550 (61)
Y axis	mm(in)	±220 (8.66)
B axis	mm(in)	240° (-10° ~ +230°)
CHUCK SPINDLE		
Spindle speed range	rpm	2500
Chuck size	in	12
Type of spindle nose		A2-8
Spindle motor power	KW(HP)	30 (40)
ELECTRO SPINDLE		
Spindle speeds	min ⁻¹	12,000
Spindle nose		Capto C6
Spindle motor power	KW(HP)	26 (34.8)
Max. spindle torque	Nm (ft.lbf)	103 (139.6)
B Axis		
Angular Stroke	Deg	240° (-10° ~ +230°)
Brake Clamping Angular	Deg	0.0001°
Max Torque Motor Torque (continuous)	Nm	1200
A.T.C		
Tool shank		Capto C6
Tool storage capacity		40
FEEDRATE		
X axis rapid traverse	mm(in)/min	15000 (590)
Z axis rapid traverse	mm(in)/min	30000 (1181)
Y axis rapid traverse	mm(in)/min	30000 (1181)
FEED MOTORS		
X axis motor	SIEMENS KW(HP)	5.37 (7.2)
Y axis motor	SIEMENS KW(HP)	5.37 (7.2)
Z axis motor	SIEMENS KW(HP)	5.37 (7.2)
TAILSTOCK		
Tailstock movement type		Servo
Quill inside taper	M.T	5
Max. thrust	kgf	750
MISCELLANEOUS		
Power supply	KVA	75
Mass of machine	kg	9500
Machine dimensions(L)	mm(in)	6750 (266)
Machine dimensions(W)	mm(in)	3522 (138.7)
Machine dimensions(H)	mm(in)	2666 (105)

LEADWELL CNC MACHINES MFG.,CORP.

NO.23, Gong 33th Road, Taichung Industrial Park Taichung 407, Taiwan

TEL: 886-4-23591880 FAX: 886-4-23592555, 23593875

E-mail: sales@leadwell.com.tw

www.leadwell.com.tw