

LEADWELL
LEADWELL CNC MACHINES MFG., CORP.

MH-i Series
HORIZONTAL MACHINING
CENTER



MH-400i / MH-500i

MH-i Series **Horizontal Machining Center**

**Excellent
for
Diversified
Industries**

- Precision (profiled) Parts Machining
- General Mold Machining
- Automotive and Motorcycle Part Machining
- 3C Industries
- Aerospace Part Machining
- Semi-conductor Industry
- FMC & FMS Unmanned Production Lines



BALL BAR TESTING

LEADWELL uses a stringent ball bar test that checks not only linear accuracy but also machine geometry. This test insures that each machine meets the three-dimensional squareness and accuracy requirements.

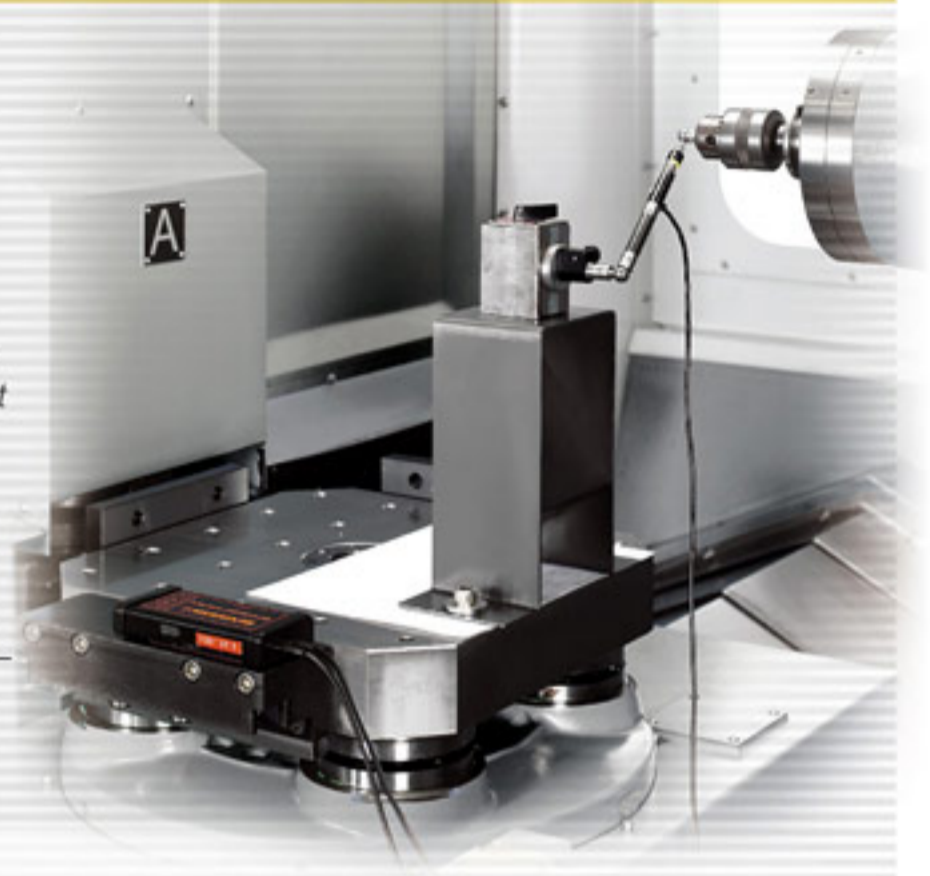

5th AXIS ROTARY TABLE OPTION

The contouring rotary tables with a minimum indexing increment of 0.001 offer simultaneous machining functions for complex profiled workpieces. Extra large preloaded thrust bearings insure smooth and accurate table rotation. Four clamping cones insure accurate and repeatable pallet location along with excellent rigidity.

SPINDLE SPEED / OUTPUT DIAGRAM

--- 30 min operating
— continuous operating

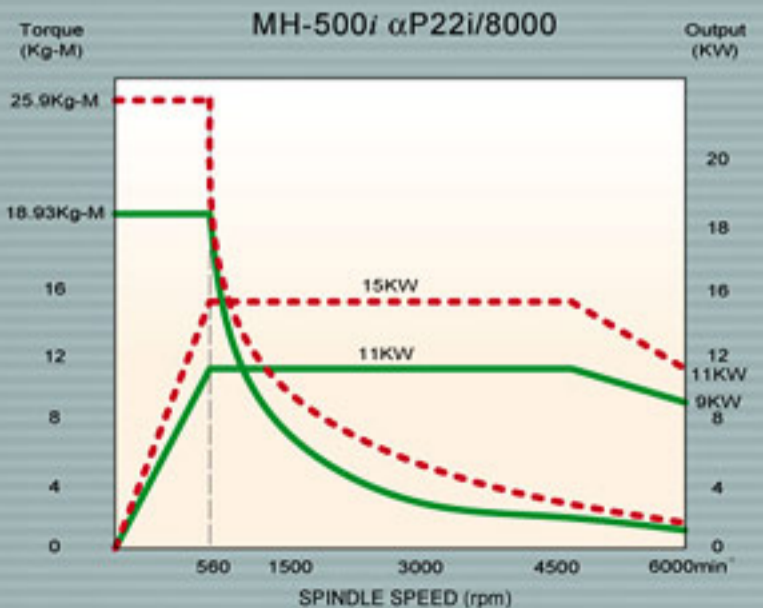
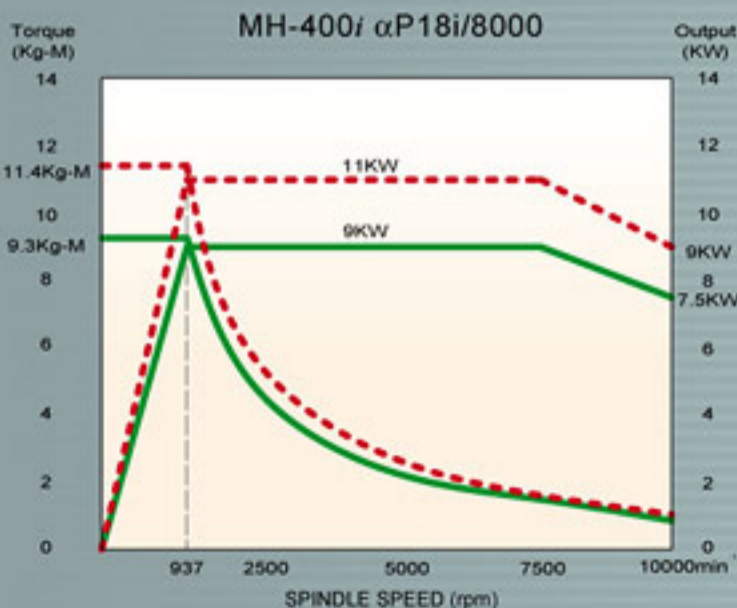

MH-i Series

Optimal Machine Structure

CAST IRON CONSTRUCTION

Leadwell uses only top quality well-ribbed castings. Finite Element Analysis (FEA) is used on each new casting to determine the size and location of all internal ribs ensuring high torsional stiffness and minimum vibration. The traveling column design reduces the required floor space and provides excellent accessibility to the machine table. Heavy duty linear guide ways insure accurate positioning and rapid travel for all axes. The cast iron base column, saddle, headstock, & tables have over 10 times the dampening capacity of those made from steel resulting in superior cutting performance.

SWING TYPE APC

The MH-Series machines have a standard 2 pallet swing type changer system. The load position at the front of the machine allows easy loading and unloading of work pieces. The pallets are positioned and clamped to the table with four precision taper cones to ensure accuracy and rigidity. During the pallet changing cycle compressed air is blown through the cones to clean the clamping surfaces, removing chips and coolant. This air assures pallet location accuracy and long component life.

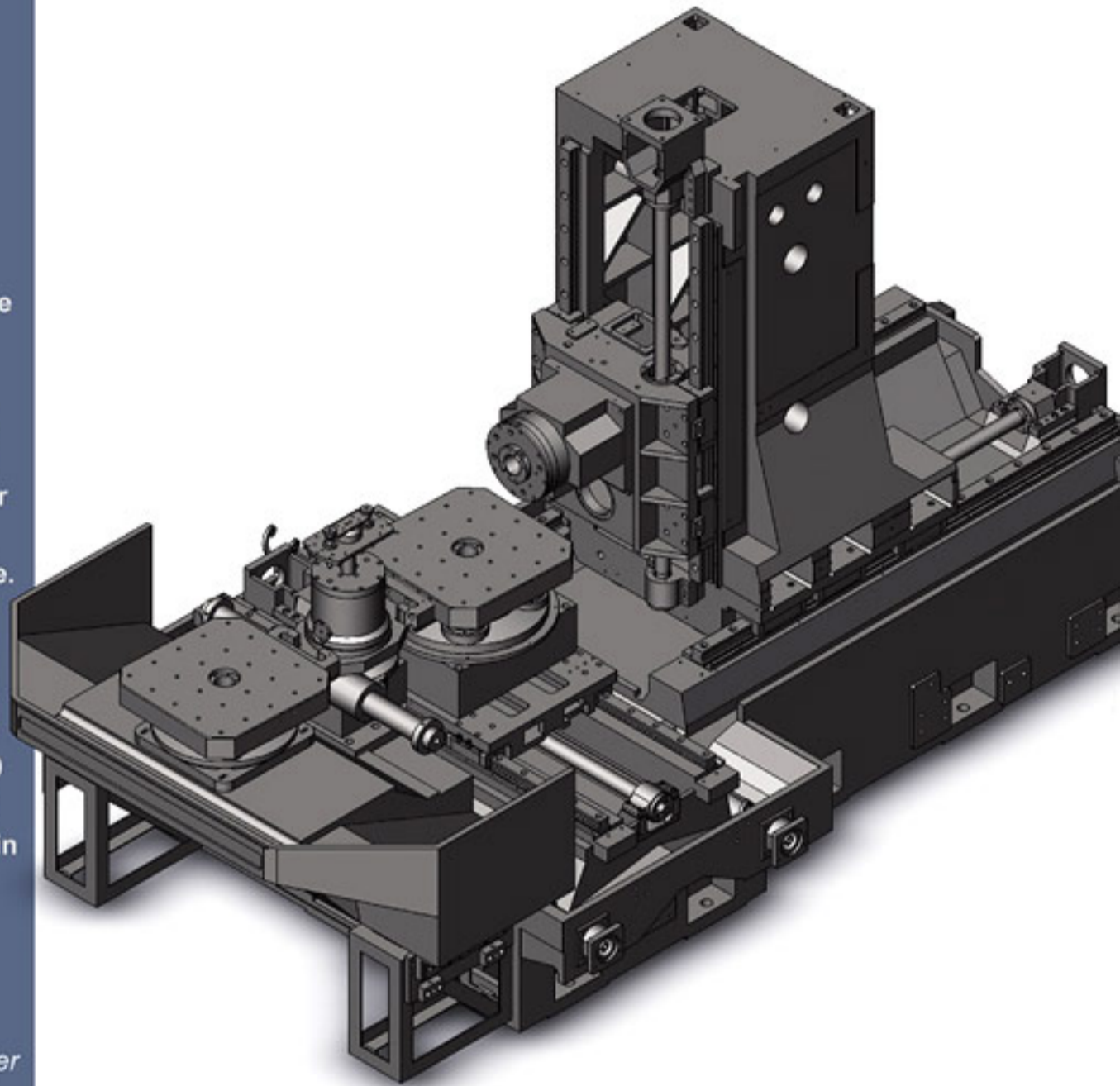

OVERSIZED TAPERED CONES

- The B axis movement and Z axis cross movement are equipped with oversized tapered cones for extremely accurate pallet positioning. This assures outstanding machining accuracy.
- Because the bigger O.D. of cones than other makers and over 75% contact surface each other for each pair. The rigidity and the repeatability of continuous cutting with 0.001 degree better than the 1 degree divided cutting.



CHAIN-TYPE MAGAZINE

Choice of 40, 60 or 90 tools for the magazine capacity.

AUTOMATIC TOOL CHANGING SYSTEM

The high-speed ATC activates a high-pressure air blast to clean the spindle taper and the ATC tool pot to ensure accurate tool holding. Tools are automatically returned to their original location, eliminating tool interference from oversized tools in the magazine.

SIDE-MOUNTED TOOLING SYSTEM

The tool magazine is isolated from the machining area. An automatic door keeps chips from contaminating the tools' tapered shanks. Having the next tool ready near the spindle during current tool machining, drastically reduces tool change time.

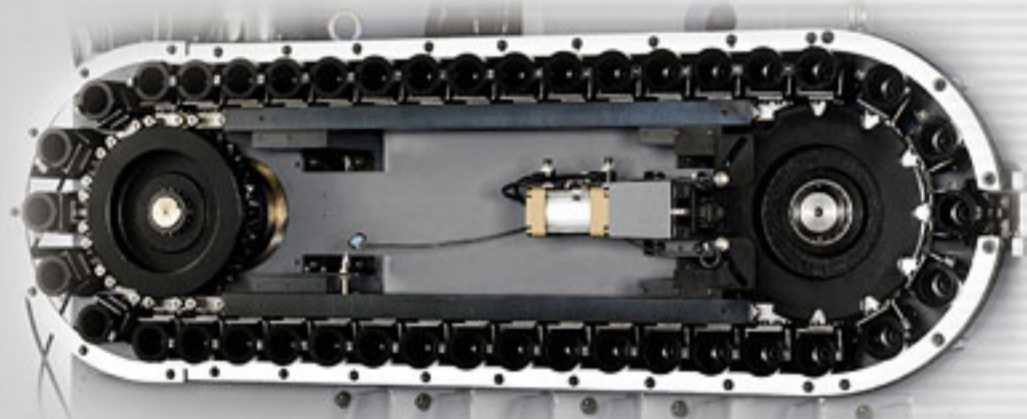

1 Driven by motor
[MH-400i Std.]

2 Driven by cylinder
[MH-500i Std.]

B AXIS

- The B axis employs oversized bearing assuring smooth and accurate rotation in vertical and horizontal directions.
- Specially-designed teeth areas on the worm and worm gear feature 50 times the loading area than that of conventional complex screws. Also, teeth wear resistance is unmatched compared to that of complex screws. It features greater durability and accuracy than that of competing machines.
- The force driving position between the worm and worm gear is a curved surface which provides 2~3 times higher driving capacity than that of conventional complex screws. With the proper driving force distribution, the backlash between teeth can be controlled under 0.01 mm.

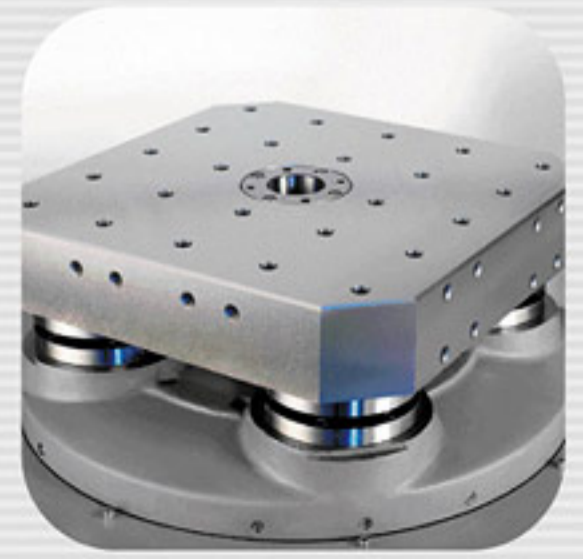

TOOL SHANK SPECIFICATIONS

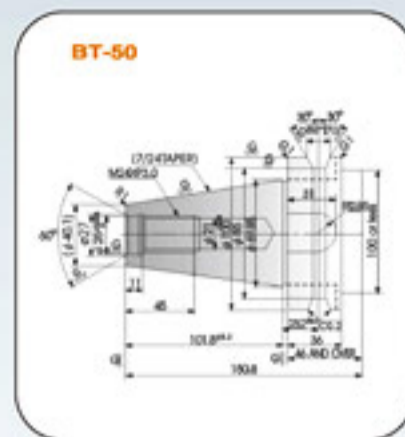
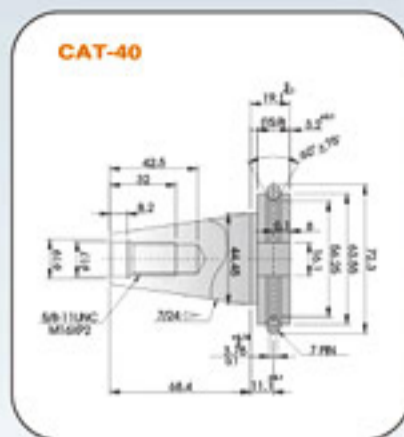
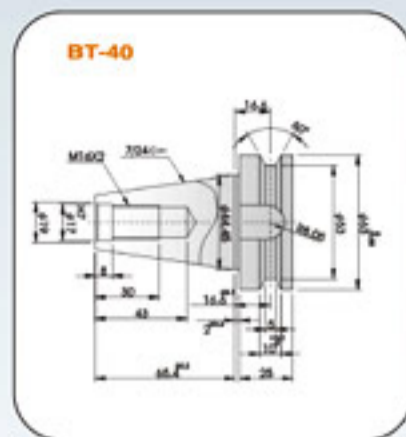

THREE AXES TRAVEL RANGE

Unit:mm

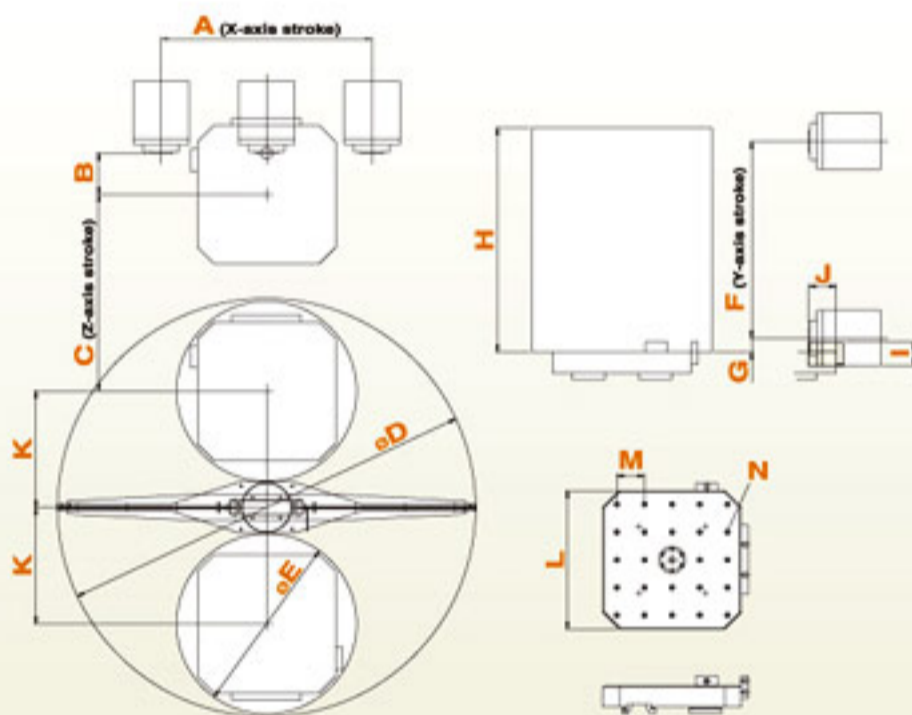

Item	Model	MH-400/ #40	MH-500/ #50
A		570	750
B		175	150
C		520	700
D		1360	1670
E		590	710
F		510	650
G		50	50
H		620	800
I		50	80
J		30	100
K		450	500
L		400x400	500x500
M		80	100
N		24-M12x1.75P	24-M12x1.75P

MACHINE DIMENSIONS

MH-400/

Unit:mm

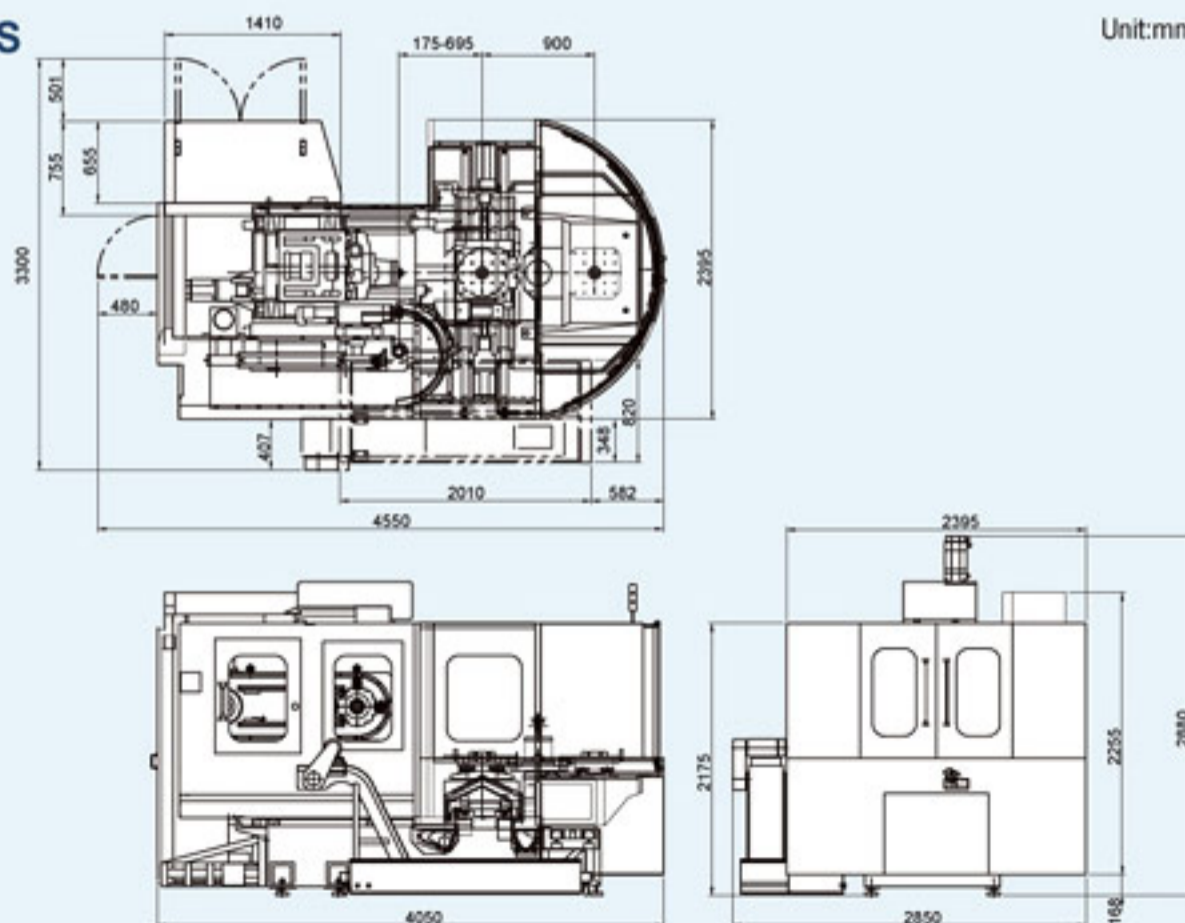

■ MACHINE SPECIFICATIONS

Item	Model	MH-400i	MH-500i
CAPACITY			
	Unit		
X axis travel	mm (in)	570 (22.4)	750 (29.5)
Y axis travel	mm (in)	510 (20)	650 (25.5)
Z axis travel	mm (in)	520 (20.4)	700 (27.5)
Distance form table top to spindle centre	mm (in)	50-560 (2-22)	50-700 (2-27.5)
Distance form table centre to spindle end	mm (in)	175-695 (6.9-27.3)	150-850 (5.9-33.4)
TABLE			
Pallet size (LxW)	mm (in)	400x400 (15.7x15.7)	500x500 (19.7x19.7)
Max. table load weight	kg (lb)	400 (880)	500 (1100)
Min. table indexing angle	deg	0.001	0.001
SPINDLE			
Spindle speeds	rpm	10000	6000
Spindle nose (nominal size, No.)		7/24 Taper, No.40	7/24 taper, NO.50
Spindle bearing inner diameter	mm (in)	70 (2.7)	90 (3.5)
FEEDRATE			
Rapid traverse X,Y,Z	M/min (IPM)	36 (1417)	30 (1181)
Max. cutting feedrate	M/min (IPM)	5 (196.8)	8 (315)
A.T.C.			
Tool storage capacity	pcs	40	40
Max. tool diameter (with adjacent tools)	mm (in)	75 (2.9)	125 (5)
Max. tool length	mm (in)	270 (10.6)	350 (13.7)
Tool change time (T-T/C-C)	sec	5/8	10.5/15
A.P.C.			
Number of pallets	pcs	2	2
Pallet changing time	sec	16	16
MOTORS			
Spindle motor (30min/cont) FANUC	kW (HP)	11 (14.7)	15 (20)
X/Y/Z axis feed motors	kW (HP)	4/4/4 (5.4/5.4/5.4)	3/4/4 (4/5.4/5.4)
MACHINE SIZE			
Height of machine	mm (in)	2880 (114)	2820 (110)
Floor space (LxW)	mm (in)	4600x3200 (181x126)	5650x3600 (222.4x141.7)
Total machine weight	kg (lb)	9500 (20948)	15000 (33000)
Power requirement	KVA	50	50
Computer control	FANUC	0i-MC	0i-MC

STANDARD ACCESSORIES

- RS232 interface
- Rigid tapping
- Fully enclosure guarding
- Chip conveyor(auger type)
- Work light
- Alarm lamp
- Heat exchanger
- Remote MPG
- Coolant system including coolant tank
- Lubrication system
- Leveling screws and pads
- Maintenance tool box
- Spindle oil collar(chiller)
- Rotary table 0.001°
- 6000rpm spindle (MH-500i)
- 10000rpm spindle (MH-400i)
- Tool tip air blow system
- Air purge
- Shower coolant system
- Chip conveyor outside machine & chip bucket
- Coolant gun (MH-400i)
- Auto counter for work piece
- Arm A.T.C with 40 tool magazine

OPTIONAL ACCESSORIES

- 8000rpm spindle
- Two speed gearbox (MH-500i)
- C.T.S. preparation
- Linear scales
- Tool overload detection
- Auto tool length measurement
- Automatic workpiece measurement
- Simple tool life management
- Coolant gun (MH-500i)
- Through hole drill kit
- DNC link software
- Arm A.T.C with 60 tool magazine (MH-500i)
- Arm A.T.C with 90 tool magazine (MH-400i)
- Automatic power off
- Oil collector
- Air conditioner in cabinet

■ MACHINE DIMENSIONS MH-500i

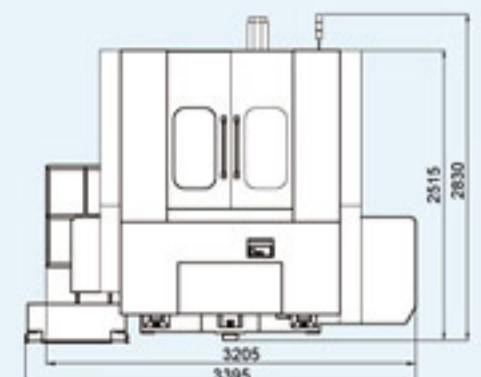
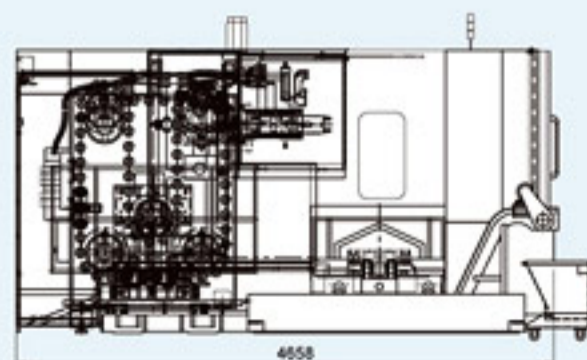
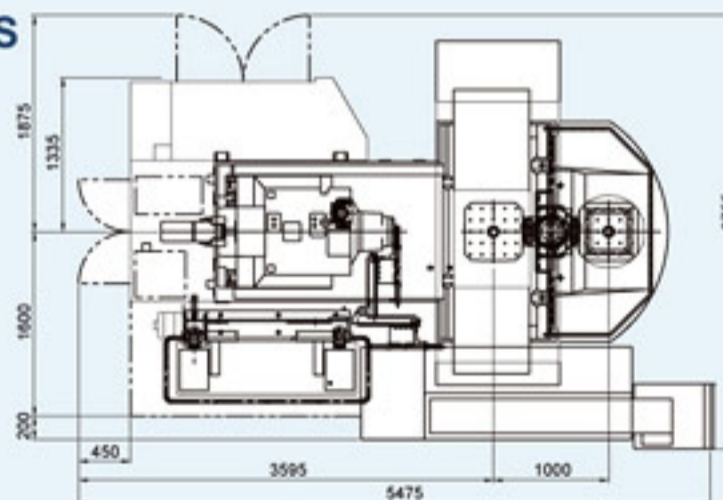

Unit:mm

LEADWELL CNC MACHINES MFG.,CORP.

NO.23, Gong 33th Road, Taichung Industrial Park

Taichung 407, Taiwan

TEL: 886-4-23591880

FAX: 886-4-23592555, 23593875

E-mail: sales@leadwell.com.tw

www.leadwell.com.tw