

**LEADWELL**  
LEADWELL CNC MACHINES MFG., CORP.

# **LTC-25**

## **CNC TURNING CENTER**



*For Optimum Results in  
Machining Efficiency*

# Saves Time! Saves Costs!

## The Leadwell **LTC-25** Differs - Innovative Design Concepts for Greater Capacity

- A medium sized CNC Turning Center with box ways on all axes.
- 85 mm. larger hole (LTC-25BL) through spindle compared to competing models.
- Excellent for cutting long parts.
- Maximum stability and rigidity.
- Extra powerful  $\alpha$ P30(18.5KW / 24.8HP) spindle motor.  
 $\alpha$ P40(22KW / 29.5HP) motor is optional.

### The Best Way for Productivity and Profitable Production

LEADWELL LTC Series Slant Bed CNC Turning Center is designed and engineered to operate efficiently and precisely with virtually minimum trouble. When you place a LEADWELL LTC series Turning Center in your workshop, you will obtain maximum dependability for operational performance year after year. Compared to the competing models, the LEADWELL LTC series features higher stability in construction. This means absolutely minimized vibration. In addition, higher metal removing rate and accuracy are designed into each model in LTC series. Our objective is to keep your business staying competitive and creating profits.





# LTC-25

# LEADWELL Guarantees and Accuracy All Time

## Massive Construction Slant Bed

### Headstock

The headstock is a thermally symmetric design with heat dissipating fins. This design prevents thermal distortion during long machining cycles.

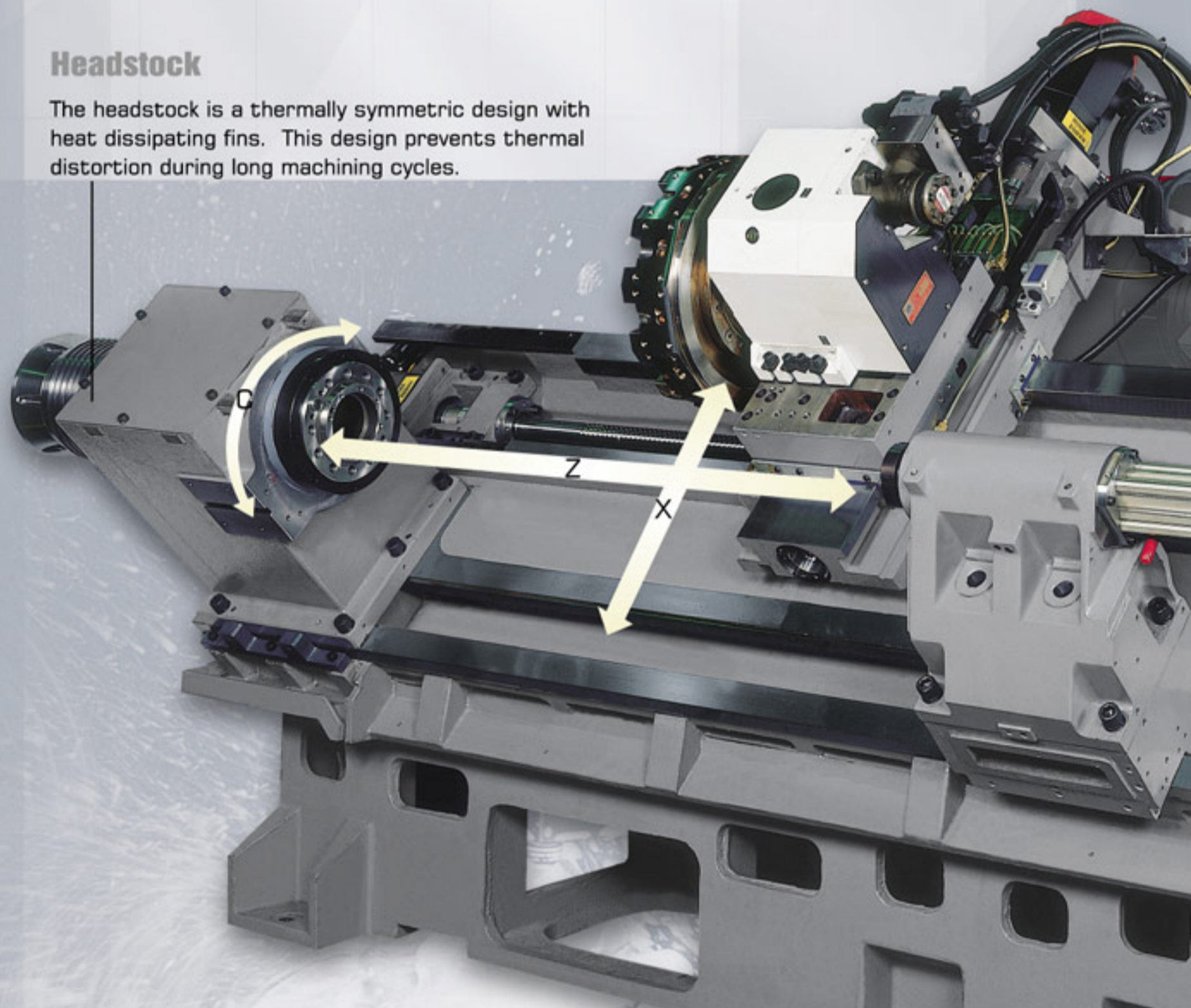

| TRAVEL | LTC-25AL<br>LTC-25BL | LTC-25ALM<br>LTC-25BLM |
|--------|----------------------|------------------------|
| X axis | 210+20mm (8.2"+0.7") | 235+20mm (9.2"+0.7")   |
| Z axis | 1090mm (42.9")       | 1090mm (42.9")         |

# See Superior Stability in Action!

LEADWELL turning centers are of rigid construction to give a high degree of machining accuracy year after year. Rigid cast iron construction allows consistent, deformation-free precision machining.

## Here are the keys to the optimum structure:

- Leadwell uses only top quality well-ribbed castings.
- Advanced Finite Elements Analysis (FEA) is used for analyzing new casting to determine the size and location of all internal ribs, ensuring high torsional stiffness and minimum vibration.
- The cast iron base, saddle, headstock, slide and tailstock are ruggedly constructed for superior stability and machining accuracy.

### Easy Chip Disposal

- The 45-degree slant bed design allows chips to fall directly into the chip tank, avoiding accumulation inside the machine.
- The chip tank has large wheels, making it easy to move for chip removal and cleaning.
- Chain-type chip conveyor (optional) available on all models.



## High Chip Removal Rate - Easier Than Ever!

When your operations require higher efficiency to stay competitive, LEADWELL'S LTC-25 can help you.

### Cutting Tests Report

#### O.D. TURNING

| Cutting Feedrate<br>M/min. | Cutting depth<br>mm. | Feedrate<br>mm/rev. | Chip Removal Rate<br>c.c./min. | Workpiece Material     |
|----------------------------|----------------------|---------------------|--------------------------------|------------------------|
| 200                        | 8                    | 0.4                 | 704                            | Mild Carbon Steel S45C |

#### SLOTING ON O.D.

| Cutting Feedrate<br>M/min. | Slot Width<br>mm. | Feedrate<br>mm/rev. | Distance from Chuck Face | Workpiece Material     |
|----------------------------|-------------------|---------------------|--------------------------|------------------------|
| 100                        | 5                 | 0.08                | 320                      | Mild Carbon Steel S45C |

#### DRILLING

| Cutting Feedrate<br>M/min. | Hole Dia.<br>mm. | Feedrate<br>mm/rev. | Spindle Speed<br>rpm | Workpiece Material           |
|----------------------------|------------------|---------------------|----------------------|------------------------------|
| 157                        | 50               | 0.15                | 1000                 | Chrome-Molybdenum<br>SCM 440 |

# Quality Features Performance



## EXTRA WIDE SPAN FOR INCREASED STABILITY

- The LTC series utilizes oversized box ways for high horse power machining. The extremely rigidity body base frame with the box ways provides outstanding stability for precision turning.



## Rugged Tailstock

- The heavy-duty tailstock is attached to the lower guide of the machine base. The heavy casting, large diameter quill and precision morse taper center provide outstanding rigidity.
- The quill adjustment is hydraulic, adding the rigidity of the machine.
- Programmable Tailstock (optional): Available on all models.
- Rotary Tailstock (optional): Available on all models.

# Guarantee Greater

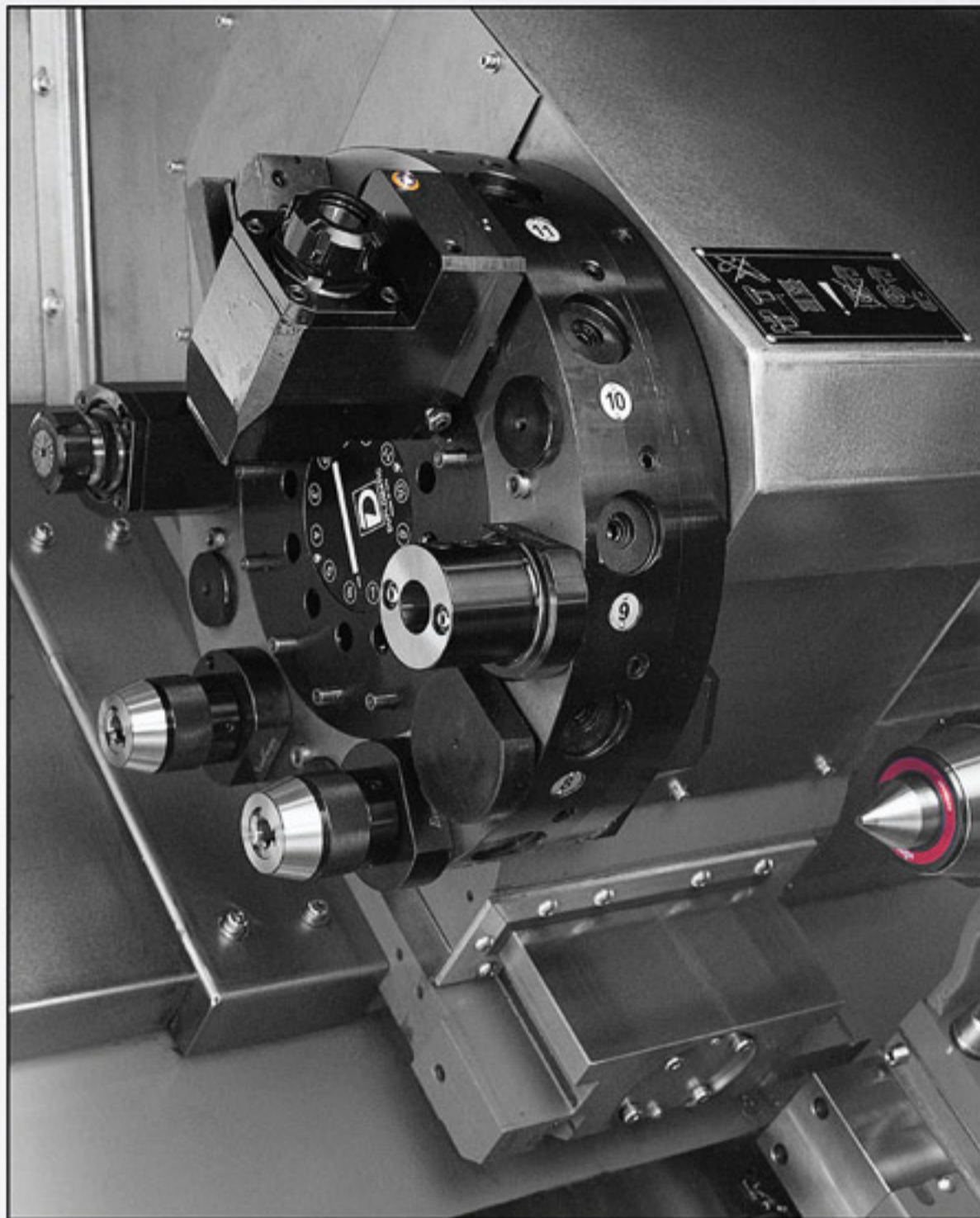

## Heavy Duty Turret

The T/LTC Series Turret features a robust casting and a large coupling face adding extreme rigidity to the machine. This added rigidity provides increased metal removal rates, extends tool life, enhances finishing quality, and ensures long term accuracy.

A reliable high torque hydraulic indexing motor controls turret rotation, deceleration and clamping. Turret indexing is bi-directional with 0.25 second station-to station indexing time.

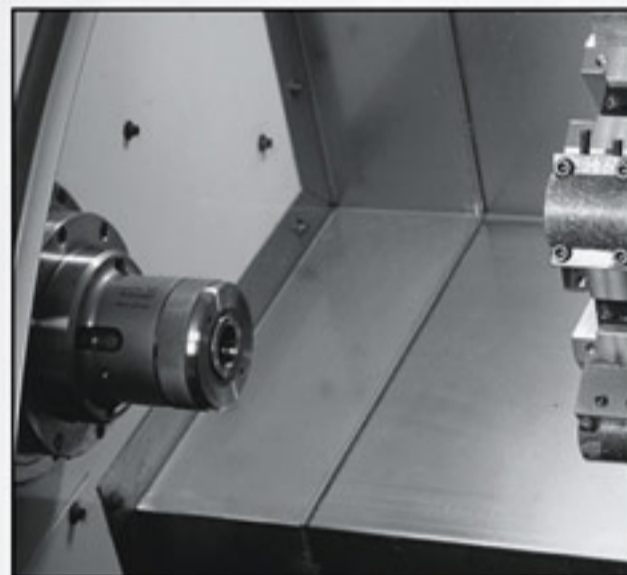

## Machine Enclosure

The machine is fully enclosed with splash-guards and way covers. CE approved guarding option includes tempered glass in the operator window.



## DOUBLE NUT BALL SCREWS

- Leadwell uses only premium quality preloaded double-nut ball screws from THK, PMI, Rexorthe (STAR) and HIWIN. Each ball screw is accurately aligned parallel to the guide ways and anchored at both ends.
- Ball screws are pretensioned to improve machine stiffness. The rotational torque variation is inspected to guarantee non-binding, highly accurate, and long running components. This assures lifetime accuracy and maximum service life.

## High Productivity Options

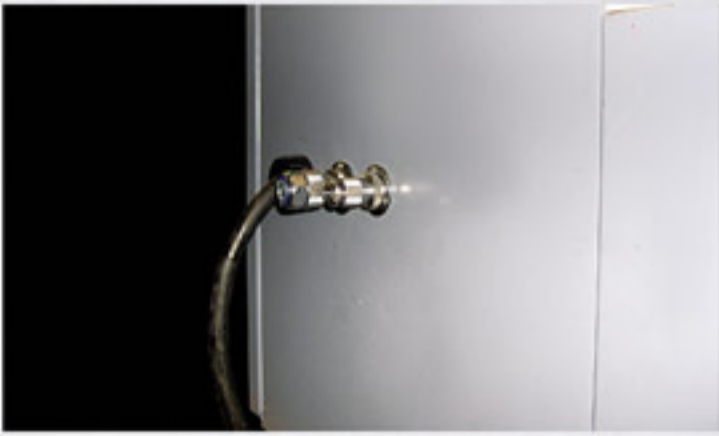

### MULTI-PROCESSING OPTIONS

Most turned parts require additional machining procedures such as milling, drilling, tapping, etc. Leadwell offers two options that turn their CNC lathes to become multi-process turning centers. These options provide the benefits of a lathe, plus extra versatility of a machining center. This allows faster production time and higher efficiency all in one package.

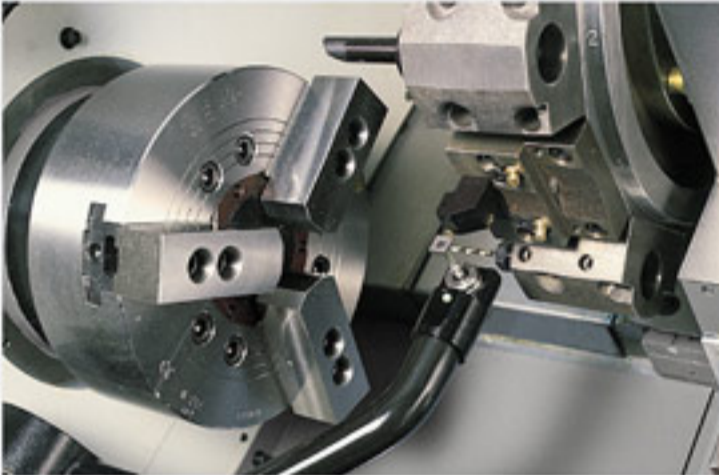

### TOOL SETTER (OPTIONAL)

The tool setter has a touch sensor that can measure varying tool lengths and detect broken tools. It can be easily programmed to store all the tool information to reduce tool changing time.

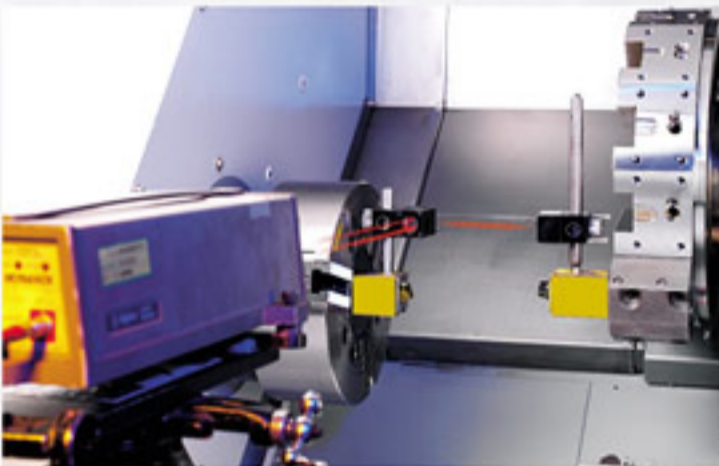

### LASER INSPECTION

An advanced laser instrument is employed for inspecting and compensating linear accuracy and pitch error. This assures optimum axis travel accuracy.

## With C-axis to Achieve Versatility and Productivity

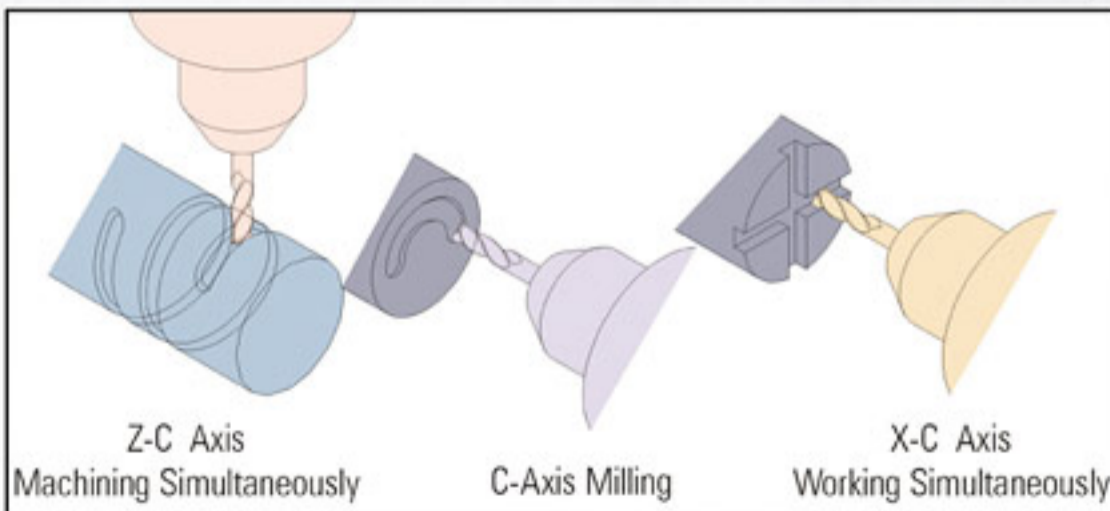

### C-AXIS

The headstock spindle becomes fully programmable servo axes with the C-axis option.

- C-axis index resolution: 0.001 °.
- C-axis rapid rate: 40 rpm.

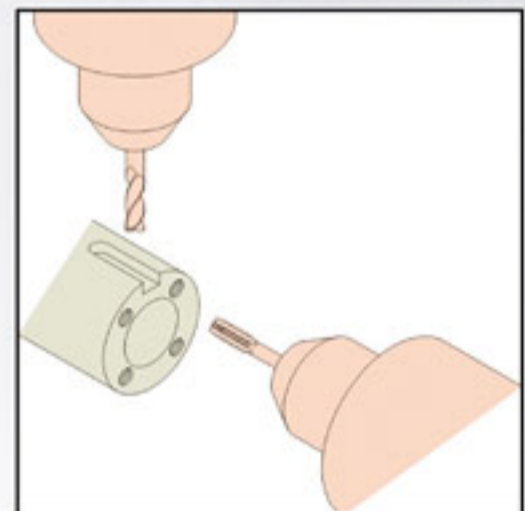

### LIVE TOOLING OPTION

The Live Tooling option turns the turret into multiple auxiliary spindles. The turret spindle supports milling, drilling and tapping.

## ■ Tooling System

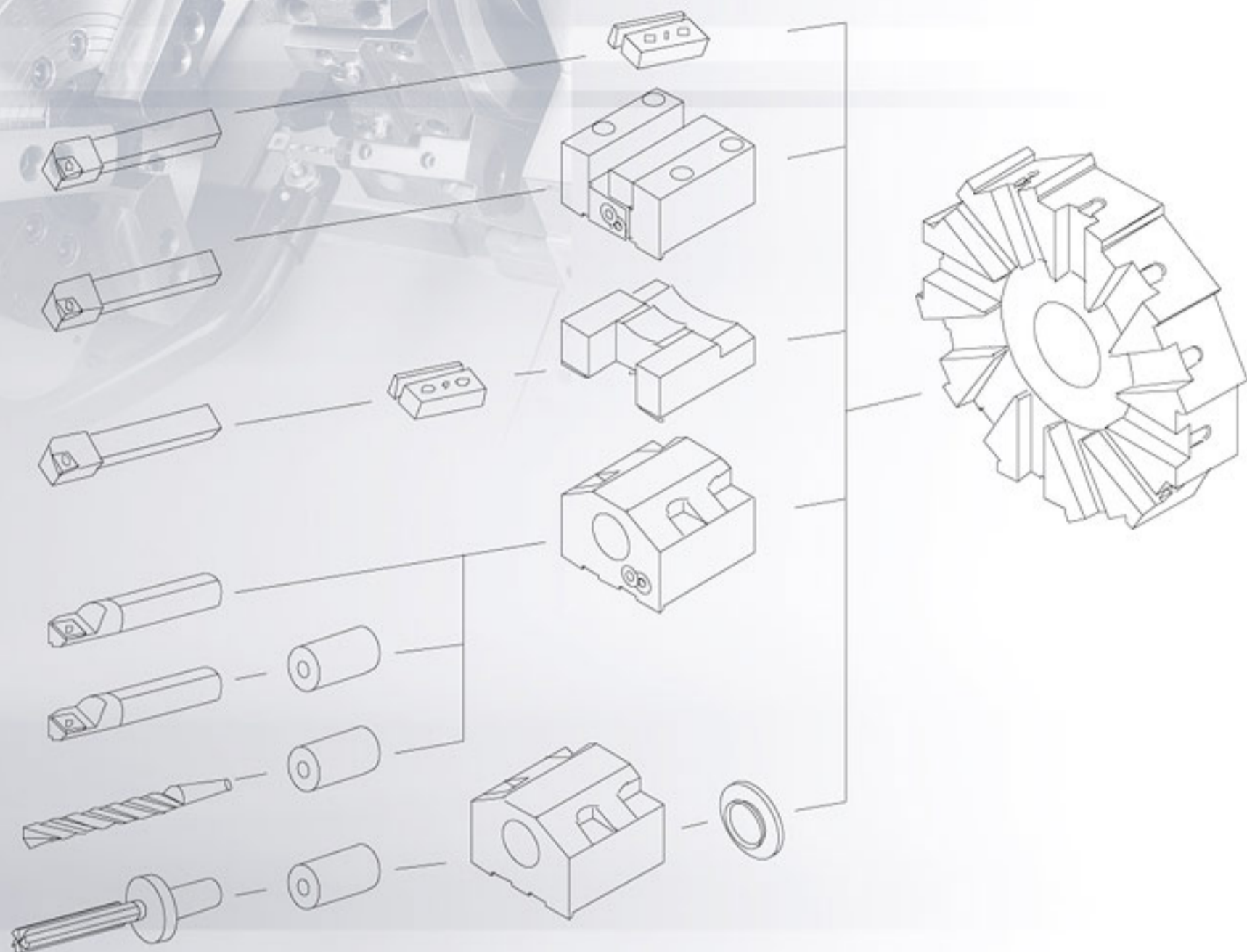

## ■ Tooling Interference

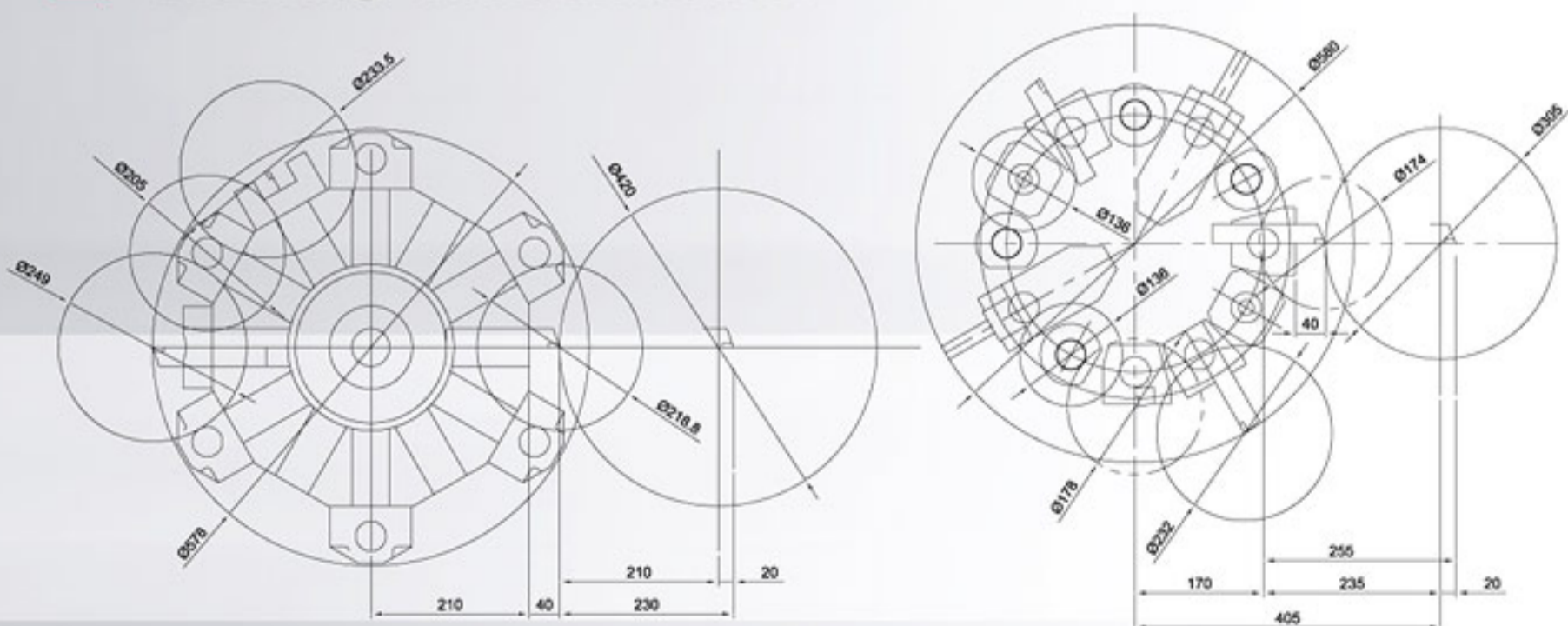



## Machine Specifications

| <b>CAPACITY</b>                             | <b>LTC-25AL</b>       | <b>LTC-25AL(opt.)</b> | <b>LTC-25ALM</b>      | <b>LTC-25ALM(opt.)</b> | <b>LTC-25BL</b>       | <b>LTC-25BL(opt.)</b> |
|---------------------------------------------|-----------------------|-----------------------|-----------------------|------------------------|-----------------------|-----------------------|
| Max. swing                                  | Ø680mm (26.7")        |                       | Ø680mm (26.7")        |                        | Ø680mm (26.7")        |                       |
| Swing over cross slide                      | Ø426mm (16.7")        |                       | Ø426mm (16.7")        |                        | Ø426mm (16.7")        |                       |
| Max. turning diameter                       | Ø420mm (16.5")        |                       | Ø305mm (12")          |                        | Ø420mm (16.5")        |                       |
| Max. turning length                         | 1050mm (41")          |                       | 1050mm (41")          |                        | 1050mm (41")          |                       |
| Bar capacity                                | Ø78 mm (3")           |                       | Ø78 mm (3")           |                        | Ø85 mm (3.3")         |                       |
| Max. workpiece weight (with tailstock)      | 500kg                 |                       | 500kg                 |                        | 500kg                 |                       |
| <b>TRAVEL</b>                               |                       |                       |                       |                        |                       |                       |
| X axis                                      | 210+20mm (8.2"+0.7")  |                       | 235+20mm (9.2"+0.7")  |                        | 210+20mm (8.2"+0.7")  |                       |
| Z axis                                      | 1090mm (42.9")        |                       | 1090mm (42.9")        |                        | 1090mm (42.9")        |                       |
| <b>SPINDLE</b>                              |                       |                       |                       |                        |                       |                       |
| Spindle speed range                         | 3500 rpm              |                       | 3500 rpm              |                        | 3200 rpm              |                       |
| Chuck size                                  | 254mm (10")           |                       | 254mm (10")           |                        | 304mm (12")           |                       |
| Type of spindle nose                        | A2-8                  |                       | A2-8                  |                        | A2-8                  |                       |
| Through spindle hole diameter               | Ø95mm (3.7")          |                       | Ø95mm (3.7")          |                        | Ø95mm (3.7")          |                       |
| Front bearing ID/OD                         | 130/200mm (5.1"/7.9") |                       | 130/200mm (5.1"/7.9") |                        | 130/200mm (5.1"/7.9") |                       |
| Spindle motor type (Fanuc)                  | $\alpha$ p30/6000i    | $\alpha$ p40/6000i    | $\alpha$ p30/6000i    | $\alpha$ p40/6000i     | $\alpha$ p30/6000i    | $\alpha$ p40/6000i    |
| Spindle motor power                         | 18.5KW (25HP)         | 22KW (30HP)           | 18.5KW (25HP)         | 22KW (30HP)            | 18.5KW (25HP)         | 22KW (30HP)           |
| <b>TURRET</b>                               |                       |                       |                       |                        |                       |                       |
| Number of tool stations                     | 12                    |                       | 12                    |                        | 12                    |                       |
| Shank height for square tool                | 25mm (1")             |                       | 25mm (1") VDIØ40      |                        | 25mm (1")             |                       |
| Shank diameter for boring bar               | Ø40mm (1.5")          |                       | Ø40mm (1.5") VDIØ40   |                        | Ø40mm (1.5")          |                       |
| Turret indexing time (one tool)             | 1 sec                 |                       | 0.25 sec              |                        | 1 sec                 |                       |
| Turret indexing time (180 deg)              | 3 sec                 |                       | 0.79 sec              |                        | 3 sec                 |                       |
| Rotary tool spindle speed range: Axis units | —                     |                       | 3000 rpm              |                        | —                     |                       |
| Rotary tool spindle speed range: Rad units  | —                     |                       | 3000 rpm              |                        | —                     |                       |
| Rotary tool motor type (Fanuc)              | —                     |                       | $\alpha$ 3            |                        | —                     |                       |
| Rotary tool motor power                     | —                     |                       | 5.5Kw (7.3HP)         |                        | —                     |                       |
| <b>FEEDRATE</b>                             |                       |                       |                       |                        |                       |                       |
| X axis rapid traverse                       | 15000mm (590.5") /min |                       | 15000mm (590.5") /min |                        | 15000mm (590.5") /min |                       |
| Z axis rapid traverse                       | 20000mm (787") /min   |                       | 20000mm (787") /min   |                        | 20000mm (787") /min   |                       |
| <b>TAILSTOCK</b>                            |                       |                       |                       |                        |                       |                       |
| Quill movement type                         | Hydraulic             |                       | Hydraulic             |                        | Hydraulic             |                       |
| Quill stroke                                | 100mm (3.9")          |                       | 100mm (3.9")          |                        | 100mm (3.9")          |                       |
| Quill diameter                              | Ø100mm (3.9")         |                       | Ø100mm (3.9")         |                        | Ø100mm (3.9")         |                       |
| Quill inside taper                          | M.T. 5                |                       | M.T. 5                |                        | M.T. 5                |                       |
| <b>MISCELLANEOUS</b>                        |                       |                       |                       |                        |                       |                       |
| Power supply                                | 40 KVA                |                       | 40 KVA                |                        | 40 KVA                |                       |
| Mass of machine                             | 5200 kg               |                       | 5200 kg               |                        | 5200 kg               |                       |
| Machine dimension (L)                       | 3783mm (149")         |                       | 3783mm (149")         |                        | 3783mm (149")         |                       |
| Machine dimension (W)                       | 1851mm (73")          |                       | 1851mm (73")          |                        | 1851mm (73")          |                       |
| Machine dimension (H)                       | 1955mm (77")          |                       | 1955mm (77")          |                        | 1955mm (77")          |                       |

All performance are based on 220V/3PH/60HZ.  
Specification are subject to change without notice.

## Machine Dimensions

### LTC-25BLM | LTC-25BLM(opt.)

Ø680mm (26.7")  
 Ø426mm (16.7")  
 Ø305mm (12")  
 1050mm (41")  
 Ø85 mm (3.3")  
 500kg

235+20mm (9.2"+0.7")  
 1090mm (42.9")

3200 rpm  
 304mm (12")  
 A2-8  
 Ø95mm (3.7")  
 130/200mm (5.1"/7.9")  
 αp30/6000i αp40/6000i  
 18.5KW (25HP) 22KW (30HP)

12  
 25mm (1") VDIØ40  
 Ø40mm (1.5") VDIØ40  
 0.25 sec  
 0.79 sec  
 3000 rpm  
 3000 rpm  
 α3  
 5.5Kw (7.3HP)

15000mm (590.5") /min  
 20000mm (787") /min

Hydraulic  
 100mm (3.9")  
 Ø100mm (3.9")  
 M.T. 5

40 KVA  
 5200 kg  
 3783mm (149")  
 1851mm (73")  
 1955mm (77")

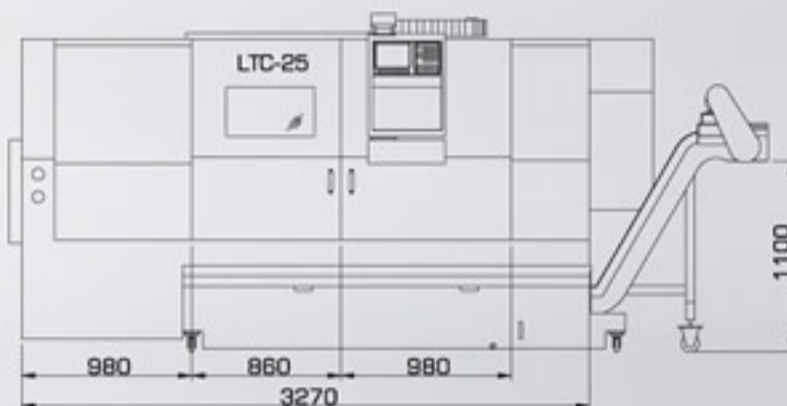
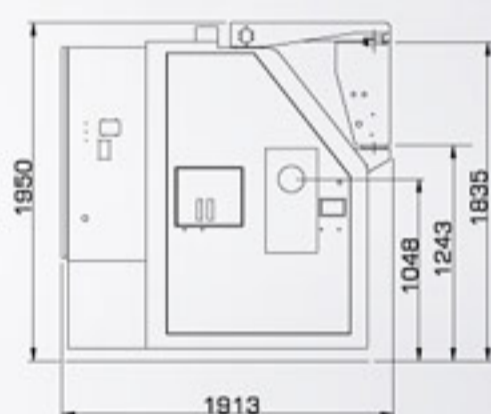
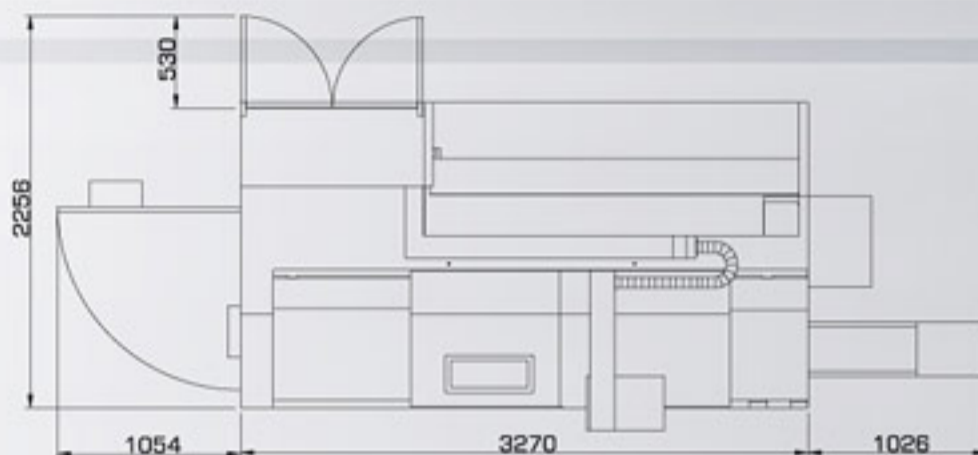

### Standard Accessories

- Chuck
- Chuck cylinder
- Soft jaw
- Hard jaw
- Face & I..D. holder (M)
- O.D. holder
- Claming block & claming gib (M)
- Level block
- Foot switch
- Tool box
- Boring bar holder Ø20 / Ø25 / Ø32
- Boring bar holder MT#1, MT#2, MT#3, MT#4
- Heat exchanger

### Optional Accessories

- Throw-away drill holder
- Holder cover
- Throw-away drill socket Ø20 / Ø25 / Ø32
- Boring bar sleeve Ø8 / Ø10 / Ø12
- Chip conveyor
- Bucket tank
- Programmable tailstock
- Steady rest
- Alarm lamp

## **LEADWELL CNC MACHINES MFG., CORP.**

No. 23, Gong 33th Road, Taichung Industrial Park,  
Taichung 407, Taiwan.

TEL: +886-4-2359-1880

FAX: +886-4-2359-2555

FAX: +886-4-2359-3875

E-mail: [sales@leadwell.com.tw](mailto:sales@leadwell.com.tw)

[www.leadwell.com.tw](http://www.leadwell.com.tw)

**LEADWELL CNC MACHINES MFG., CORP.**